

April 13, 2026

POLK COUNTY, A POLITICAL SUBDIVISION OF THE STATE OF FLORIDA

ADDENDUM #1 BID# 26-193, AG CENTER LIVESTOCK BARN PAINT PROJECT

This addendum is issued to clarify, add to, revise and/or delete items of the Contract Documents for this work. This Addendum is a part of the Contract Documents and acknowledgment of its receipt shall be noted below and on the Bid Submittal Form.

Contained within this addendum: extension of receiving date, questions and answers

The Receiving Period has been extended to Wednesday, April 22, 2026, prior to 2:00 p.m.

Brad Howard

Brad Howard
Sr. Procurement Analyst
Procurement Division

This Addendum sheet should be signed and submitted with your bid submittal.

Signature: _____

Printed Name: _____

Title: _____

Company: _____

BID 26-193, AG CENTER LIVESTOCK BARN PAINT PROJECT

ADDENDUM #1

- Q1: Has the existing paint been tested for lead?
A1: Yes, measurements were collected from 13 painted building component surfaces in the barn. Exterior and interior painted building components tested had no locations with lead concentrations in excess of the U.S. Department of Housing and Urban Development (HUD) standard of 1.0 mg/cm². A copy of the report is included at the end of this addendum.
- Q2: Parts of the structural steel are inaccessible to paint without removing gutters/downspouts. Are these inaccessible areas required to be painted?
A2: No.
- Q3: Are gutters/downspouts required to be painted?
A3: Yes, they are to be painted in place.
- Q4: Are electrical/conduit pipes required to be painted?
A4: Yes, they are to be painted. The speakers and call box, once installed, need to be protected and are not to be painted.
- Q5: Are X Bracing Rods Required to be painted?
A5: Yes.
- Q6: Will simultaneous work within the project area be occurring simultaneously? If so, how will this be coordinated?
A6: No, all other work should be completed prior to painting.
- Q7: Will weekend work be permitted to expedite project completion?
A7: Yes, the awarded vendor will need to request permission from Facilities Management Project Manager and coordinate with the Project Manager and AG Center Staff.



LEAD-BASED PAINT EVALUATION REPORT OF FINDINGS

SUMMARY OF TESTING RESULTS

On April 9, 2026, a lead-based paint evaluation was performed within the Polk County AG Center Barn located at 1702 Hwy 17 South in Bartow, FL 33830. The testing was performed by Tyler Jacobs under the supervision of EPA Inspector/Risk Assessor Mr. J. Michael Bradshaw (LBP-R-1220244-2) on limited building components. Renovations of the building are planned in the future and therefore it is desired to know if building components contain lead-based paint. Representative exterior painted building components were tested by a portable X-Ray Fluorescence Analyzer (XRF) in accordance with applicable federal regulations (i.e., EPA, HUD and OSHA).

XRF measurements were collected from 13 painted building component surfaces. Exterior and interior painted building components tested had 0 locations with lead concentrations in excess of the U.S. Department of Housing and Urban Development (HUD) standard of 1.0 mg/cm².

Note, the Occupational Safety and Health Administration (OSHA) lead in construction standard 29 CFR 1926.62 does not recognize a threshold level for lead-based paint in materials. Any work conducted with materials that have a presence of lead may be regulated by OSHA. It is the contractor's responsibility to determine compliance with the OSHA standard for workers' safety and health. During the demolition process, materials hidden behind wall cavities or other enclosures may be uncovered which may require further testing not included in this report. Applicable regulations include the OSHA Lead in Construction Standard 29 CFR 1926.62, OSHA lead exposure in construction (CPL 02-02-058), and OSHA respiratory protection 29 CFR 1910.134.



Leaded Building Components

Table 1.0

LOCATION NO.	COMPONENT	SUBSTRATE	Pb mg/cm ²	COLOR
No Leaded Building Components were Detected				

Recommendations

Based on XRF testing there were no locations of lead-based paint on interior and exterior building components.

The testing data sheet and floor plan are attached to this report.

DISCLAIMER

Caution is necessary on all painted surfaces not identified containing leaded paint equal to or in excess of 1.0 mg/cm². Some repair and painting activities can generate significant lead dust worker exposure from paint below the 1.0 mg/cm² threshold.



DMC

Floor Plan

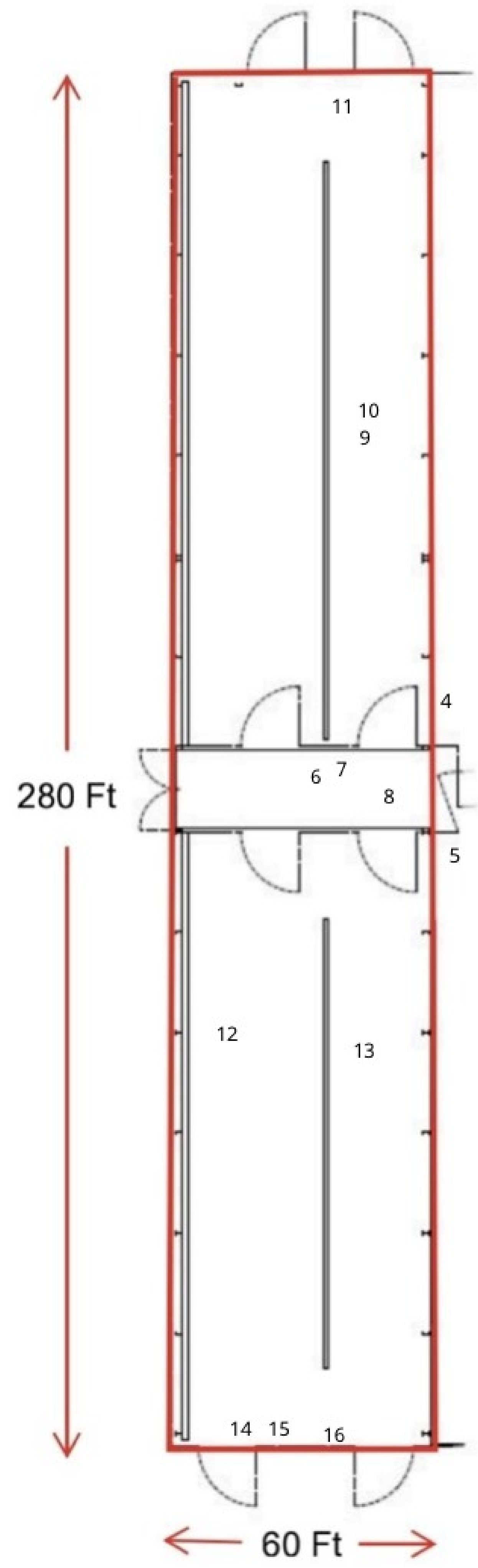

Project:

Polk County AG Center Barn
 1702 Hwy 17 South
 Barstow, FL 33830.

Location of LBP Testing(4-16)

No Locations > 1.0 mg/cm²

Prepared for:

Air Quality Consulting and Testing
 P.O. Box 1137
 Gibsonton, FL 33534

Prepared by:

Diversified
 Management &
 Construction, Inc.(DMC)
 PO Box 270010
 Tampa, FL 33688



DMC

DMC No 26-071

Drawing No.

LP-1

9 April 2026



DMC

Analytical Results XRF Data Sheets

Diversified Management & Construction
P.O. Box 270010
Tampa, FL 33688
813.322.3211 office
www.dmcincfl.com



Certifications

United States Environmental Protection Agency

This is to certify that



Diversified Management & Construction, Inc.

has fulfilled the requirements of the Toxic Substances Control Act (TSCA) Section 402, and has received certification to conduct lead-based paint renovation, repair, and painting activities pursuant to 40 CFR Part 745.89

In the Jurisdiction of:

All EPA Administered States, Tribes, and Territories

This certification is valid from the date of issuance and expires July 28, 2026

NAT-F189181-1

Certification #

July 14, 2021

Issued On



A handwritten signature in black ink that reads "Michelle Price".

Michelle Price, Chief

Lead, Heavy Metals, and Inorganics Branch

The Environmental Institute

Mike Bradshaw

Social Security Number - XXX-XX-8785
DMC - 5741 Pine Street, Mount Dora, FL 32757

"Accredited in EPA States Only"

Has completed 8 hours of coursework and satisfactorily passed the hands-on skills assessment and an examination that meets training criteria in accordance with requirements for Lead-Based Paint Activities in Target Housing and Child-Occupied Facilities as regulated by Georgia DNR/EPD Chapter 391-3-24 and U. S. EPA TSCA 40 CFR Part 745 for the refresher course titled

Lead Inspector Refresher

May 22, 2023

Course Date

May 22, 2023

Examination Date

May 22, 2026

EPA Expiration Date

2084

Certificate Number

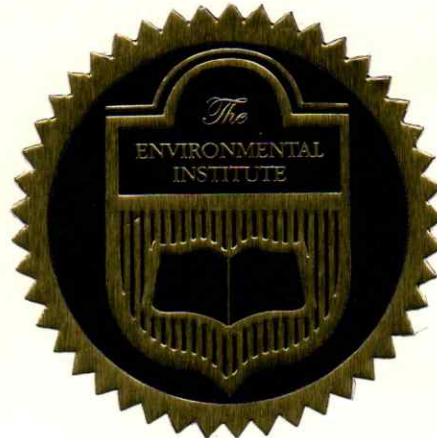

Bonnie B. Maurras- Principal Instructor/Training Manager

(Approved by the ABIH Certification Maintenance Committee for 1 CM point - Approval #11-584)

(State of Georgia Accredited - Certification No. 20-0799-006SR - September 21, 1999)

TEI - 1395 S. Marietta Parkway SE - Building 100, Suite 124 - Marietta, GA 30067

Phone: 770-427-3600 - Website: www.tei-atl.com

The Environmental Institute

Mike Bradshaw

Social Security Number - XXX-XX-8785
DMC - 5741 Pine Street, Mount Dora, FL 32757

"Accredited in EPA States Only"

Has completed 8 hours of coursework and satisfactorily passed the hands-on skills assessment and an examination that meets training criteria in accordance with requirements for Lead-Based Paint Activities in Target Housing and Child-Occupied Facilities as regulated by Georgia DNR/EPD Chapter 391-3-24 and U. S. EPA TSCA 40 CFR Part 745 for the refresher course titled

Lead Risk Assessor Refresher

May 23, 2023

Course Date

May 23, 2023

Examination Date

May 23, 2026

EPA Expiration Date

2033

Certificate Number



Bonnie B. Maurras - Principal Instructor / Training Manager



(Approved by the ABIH Certification Maintenance Committee for 1 CM point - Approval #11-584)

TEI - 1395 S. Marietta Pkwy, Bldg. 100, Suite 124- Marietta, GA 30067 - (770) 427-3600 - www.tei-atl.com

(State of Georgia Accredited - Certification No. 20-0799-006SR - September 21, 1999)

United States Environmental Protection Agency

This is to certify that



John M Bradshaw

has fulfilled the requirements of the Toxic Substances Control Act (TSCA) Section 402, and has received certification to conduct lead-based paint activities pursuant to 40 CFR Part 745.226 as:

Risk Assessor

In the Jurisdiction of:

All EPA Administered Lead-based Paint Activities Program States, Tribes and Territories

This certification is valid from the date of issuance and expires January 14, 2027

LBP-R-I220244-2

Certification #

July 17, 2023

Issued On



A handwritten signature in black ink, appearing to read "Adrienne Priselac". The signature is written in a cursive, flowing style.

Adrienne Priselac, Manager, Toxics Office
Land Division